

Connection of the 1865 Megohmmeter to a Resistivity Cell

The 1865 instrument can be used for measuring the resistivity of test samples as described by ASTM Standard D257, which details the techniques for both surface and volume resistivity measurements. The most common electrode arrangement is illustrated in Figure 1.

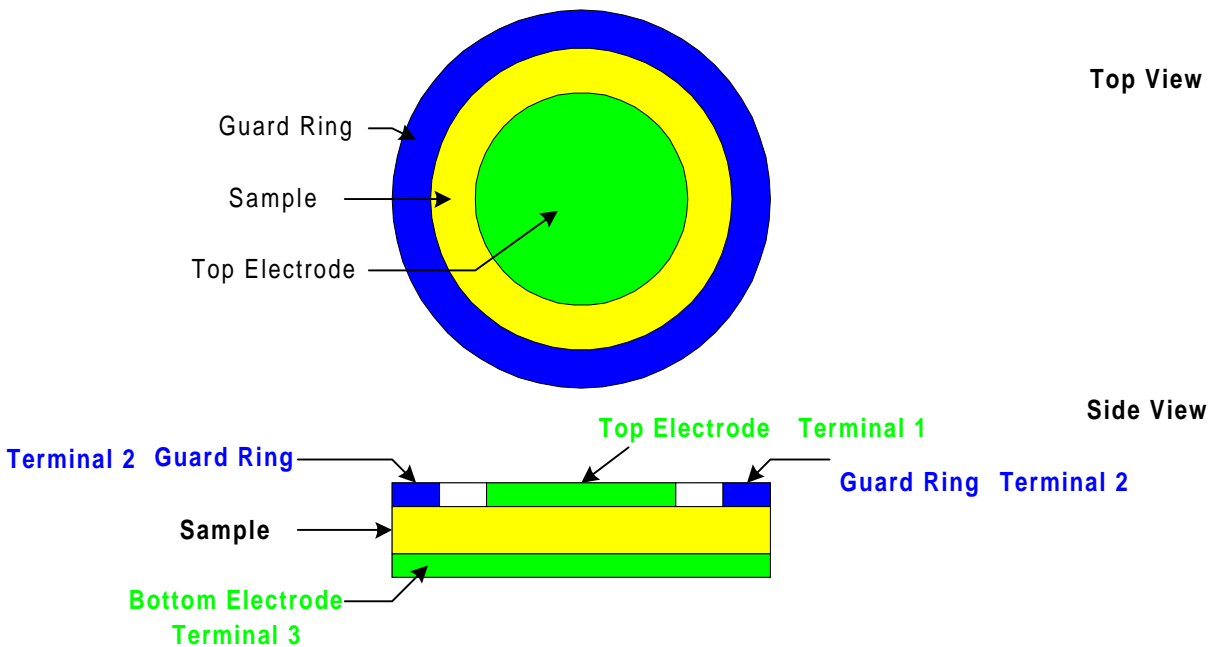

Figure 1: ASTM D257 Test Cell

In this configuration **surface** resistivity is measured with terminal 1 tied to the - UNKNOWN terminal, terminal 2 tied to the +UNKNOWN terminal and terminal 3 tied to GUARD. For volume resistivity measurements, terminal 1 is tied to the -UNKNOWN terminal, terminal 2 to the GUARD and terminal 3 to the +UNKNOWN terminal.

Table 1 provides the 1865 Output connections to the sample test cell and a formula to determine the measured resistance. Refer to the ASTM standard for the formulas required to convert from measured resistance to resistivity. Or visit the American Society for Testing and Materials at <http://www.astm.org> for the latest information.

In electrical terms, resistivity is the resistance of a material to the flow of current times the cross-sectional area of current flow per unit length of the current path.

Table 1: 1865 Output Connections to Resistivity Cell

Resistivity Test	1865 Output Terminal 1 Connection	1865 Output Terminal 2 Connection	1865 Output Terminal 3 Connection	Formula
Surface Resistivity	(-) Unknown	(+) Unknown	Guard	$P_s = \frac{P}{g} R_s$
Volume Resistivity	(-) Unknown	Guard	(+) Unknown	$P_v = \frac{A}{t} R_v$

A = effective area of the measuring electrode
 P = effective parameter of the measuring electrode
 g = dimension of space between electrode (Terminal) 2 and electrode (Terminal) 1
 t = average thickness of the specimen
 R_s = measured surface resistance in ohms (Ω)
 R_v = measured volume resistance in ohms (Ω)

Refer to ASTM D-257, Table 2 for Area (A) Formulas

Figure 2 illustrates the 1865 Megohmmeter connected to a Resistivity Cell for a surface resistivity measurement of the sample's dielectric material.

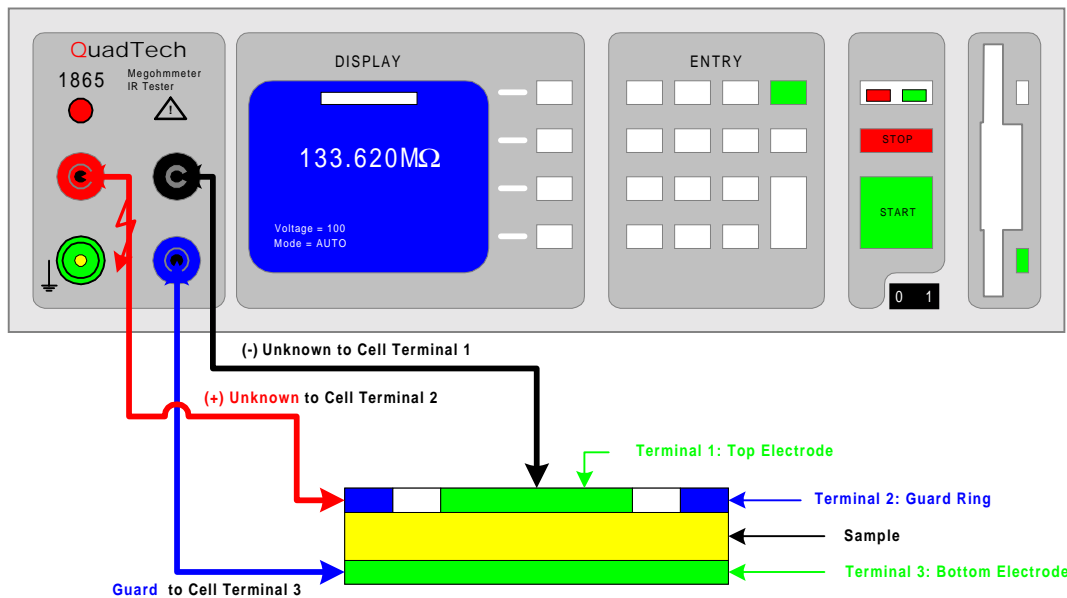

Figure 2: Connection of 1865 Megohmmeter for Surface Resistivity Measurement

For complete product specifications on the 1865 Megohmmeter/IR Tester or any of QuadTech's products, visit us at <http://www.quadtech.com/products>. Call us at 1-800-253-1230 or email your questions to info@quadtech.com.